



16574279  
Edition 1  
November 2006

# Air Percussive Needle Scaler

Model 125 and 125-EU

---

## Parts Information

**PRO** ▶  
**TECH**

Professional Technologies Sweden AB  
Munkerödsvägen 3  
444 32 STENUNGSUND  
Tel 0303-89 135 - [www.protech.nu](http://www.protech.nu)



Save These Instructions

 **Ingersoll Rand**

Model 125 and 125-EU Air Percussive Needle Scaler Exploded Diagram

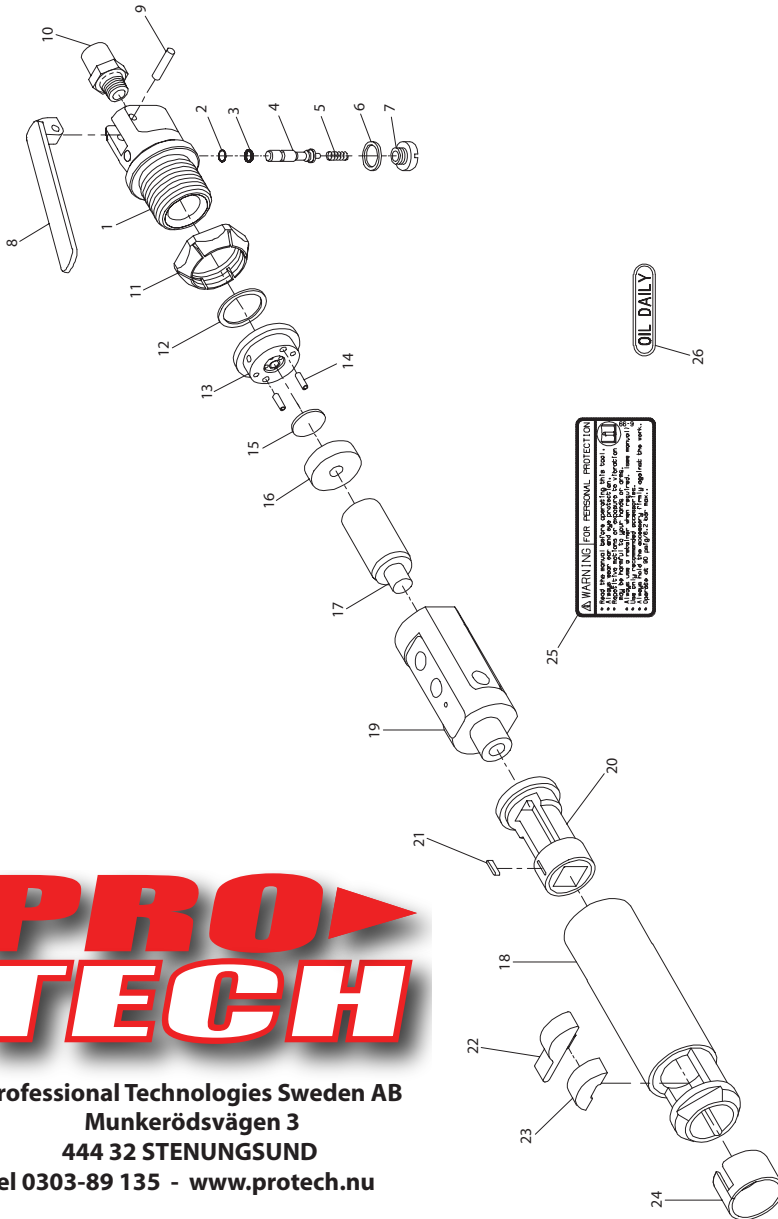

(Dwg. TPC640-2)

## Model 125 and 125-EU Air Percussive Needle Scaler Parts List

Item	Part Description	Part Number	Item	Part Description	Part Number
1	Backhead	PF2200-160		Casing Assembly	
2	Throttle Valve Stem O-Ring	PF2200-53		for model 125	PF2200-A10
3	Valve O-Ring	PF2200-50		for model 125-EU	125-EU-A10
4	Throttle Valve	PF2200-49	18	Casing	
5	Spring	PF2200-51		for model 125	PF2200-10
6	Gasket	PF2200-52		for model 125-EU	125-EU-10
7	Valve Cap	PF2200-109	19	Casing Sleeve	PF2200-30
8	Lever	PF2200-273	20	Nozzle	PF2200-7
9	Lever Pin	PF2200-274	21	Key	PF2200-8
10	Inlet Bushing	PF2200-565	22	Bit Retainer	PF2200-200
11	Locking Ring	PF2200-27	23	Bit Retainer Buffer	PF2200-203
12	Alignment Shim	PF2200-207	24	Retainer Clip	PF2200-201
13	Rear Valve Block	PF2200-4	25	Warning Label	
14	Pin (2)	PF2200-32		for model 125	WARNING-6-99
15	Valve	PF2200-2		for model 125-EU	EU-99
16	Front Valve Block	PF2200-3	26	Oil Daily Label	107-304
17	Piston	PF2200-5			

## Model 125 and 125-EU Air Percussive Needle Scaler Exploded Diagram

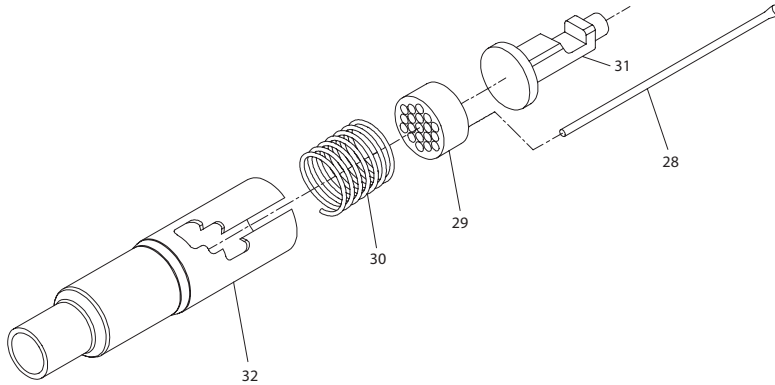

(Dwg. TPC641-1)

## Model 125 and 125-EU Air Percussive Needle Scaler Parts List

Item	Part Description	Part Number
	Needle Attachment	PF2219-K19
28	Needle Package (19)	PF2219-22-19
29	Needle Holder	PF2219-21
30	Spring	PF2219-27
31	Anvil	PF2219-20
32	Needle Housing	PF2219-24

## Parts and Maintenance

When the life of the tool has expired, it is recommended that the tool be disassembled, degreased and parts be separated by material so that they can be recycled.

Tool repair and maintenance should only be carried out by an authorized Service Center.

Refer all communications to the nearest **Ingersoll Rand** Office or Distributor.

## Related Documentation

For additional information refer to:

Product Safety Information Manual 04581450.

Product Information Manual 16574113.

Manuals can be downloaded from [www.irtools.com](http://www.irtools.com).







[www.irttools.com](http://www.irttools.com)

© 2006 **Ingersoll Rand** Company

